

ACCESSORY 3 GN 1/3 REFRIGERATED CONTAINERS YOGURT HOLDER - VEGETABLES WITH TRANSPARENT DOME - without base - CALEIDO

ACCESSORY 3 GN 1/3 REFRIGERATED CONTAINERS FOR YOGURT/VEGETABLES WITH TRANSPARENT DOME FOR BUFFET



vedi prodotto online

CODICE: **0720114172840**
MARCA: **PINTINOX BUFFET**

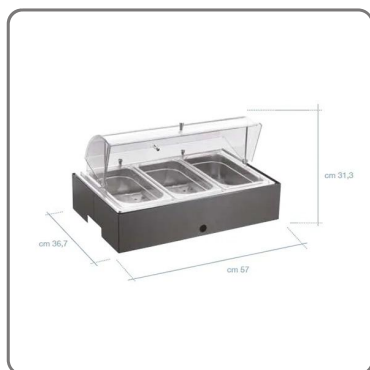

SOLUZIONI FOODSERVICE

Dimensions: cm. 57x36,7 H31,3

This refrigerated accessory is ideal for the presentation and preservation of yogurt, fresh vegetables and other cold foods in buffet settings, breakfast rooms and catering areas.

- Structure: Equipped with 3 GN 1/3 (Gastronorm) containers, it guarantees an elegant and functional presentation, with a large storage capacity for fresh ingredients.
- Material: Made of high quality materials to ensure long life and easy cleaning. The transparent dome keeps food fresh, protecting it from the external environment and allowing perfect visibility of the contents.
- Use: Perfect for buffets and breakfast rooms in hotels, restaurants and accommodation facilities. Ideal for the visible storage of yogurt, vegetables, sauces or other dishes that require constant refrigeration during service.
- Design: The transparent dome not only preserves freshness, but adds a touch of elegance to the buffet, making the product perfect for a modern and eye-catching display.

This accessory is a versatile and professional solution to improve the offering of your breakfast or buffet area, optimizing space and ensuring excellent presentation of fresh food.