

**COUNTERTOP CHAMBER VACUUM PACKAGING MACHINE bar  
cm.45 MINIPACK-TORRE MVS-X - cm.55x65x49H - 1100W**

BENCH TOP VACUUM MINIPACK TORRE TANK PRINTED BAR OIL PUMP BUSH 20 mc/h



vedi prodotto online

CODICE: MV45IA37  
MARCA: MINIPACK-TORRE

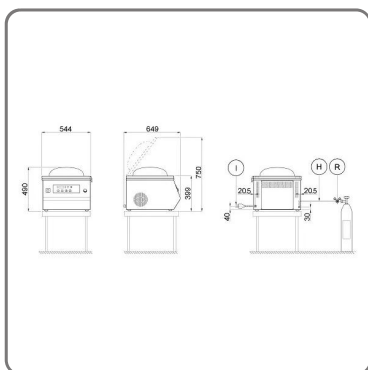

# SOLUZIONI FOODSERVICE

## CHARACTERISTICS:

- OVERALL DIMENSIONS (with lid closed) 544x649x490H
- USEFUL ROOM DIMENSIONS mm.466x405,5x226H
- BUSCH OIL PUMP OF 20 MC / H
- AISI 304 stainless steel construction
- Bell stop device included
- Vacuum cycle with stop
- Bag scrap cutting device
- Quick coupling aluminum sealing bar
- Transparent lid in plastic material for food use
- Volumetric sensor for vacuum detection
- Filling tablets in PE-HD
- 10 customizable programs and self-calibration
- Sealing bar overload safety
- Oil and assistance warning light

The MVS X line has technological and functional contents of the highest quality, but retains maximum ease of use.

The collaboration with important chefs in the construction and design phase has made it possible to enrich the functions offered by these latest generation chamber vacuum machines, taking into consideration the specific needs of professional users.

The tactile command keyboard (membran switch) is adhesive and glued to the front of the bodywork to prevent liquids from entering the board. The control panel allows you to set up to 10 customized programs, making these chamber vacuum packers very versatile products.

The display shows the need to change the oil with a specific message. The electronic sensor interprets the data directly from the card and reads the degree of vacuum created inside the chamber. Finally, it is also possible to calibrate the machine to correct any variations in atmospheric pressure at different altitudes.

IT IS RECOMMENDED TO REPLACE THE PUMP OIL ON A YEAR (more if used intensively or with hot products)